

D-POC6-MMB-S10-00-3G-*

双向液压锁



说明 DESCRIPTION

Dual pilot-operated check valve inline mounted
双向液压锁

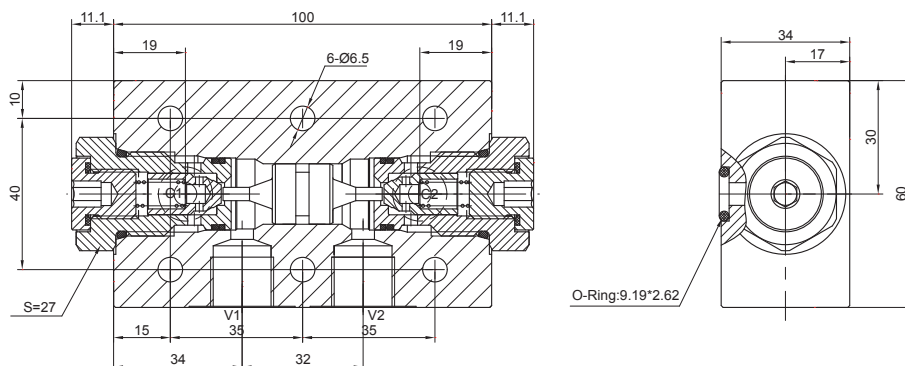

工作 OPERATION

The valve will block from “C1” to “V1” and from “C2” to “V2”. Flow is allowed in the opposite direction when pressure is applied to port “V1” or “V2”. The valve has a 7:1 pilot ratio, so at least 1/7 of the load pressure at port “C1” or “C2” is required at the pilot lines (ports “V1” or “V2”) to open the flow passage to allow flow from ports “C1” or “C2”.
C1 到 V1, C2 到 V2 关闭。在相反方向, V1 到 C1, V2 到 C2 打开。控制比为 7:1, 所以在 V1 口或 V2 口的压力超过 C1 口或 C2 口的负载压力的 1/7 时, C1 到 V1 或 C2 到 V2 打开。

SYMBOL

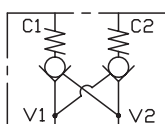

压力 - 流量曲线 PRESSURE DROP VS.FLOW

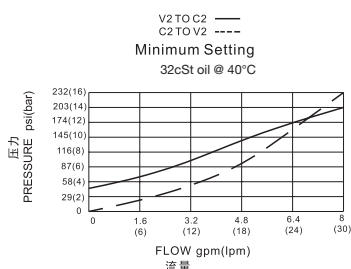

技术参数 SPECIFICATIONS

最大工作压力(Max.Operating Pressure):	350bar
流量(Flow):	See PRESSURE DROP VS.FLOW graph.
控制比(Pilot Ratio):	7:1
内泄漏(Internal Leakage):	2 drops/min(滴/分). max. at 350 bar
单向阀开启压力(Crack Pressures):	00=1.0bar; 8=8bar; 4.5=4.5bar; 3=3bar
温度(Temperature):	-40°F to +250°F(-40°C to +120°C)
过滤(Filtration):	See page (参见) N-1
油液(Fluids):	Mineral-based fluids with viscosities of 7.4 to 420 cSt.(矿物油粘度)
阀块材料(Body Material):	Steel & Ductile iron rated to 350bar 钢和球铁允许使用最大压力350bar

订货代号 TO ORDER

D - POC6 - MMB - S10 - 00 - * 3G - *

1
2
3
4
5
6
7

- | | | |
|--|---|---|
| <p>1 功能
D-POC6= 双向液压锁
Dual Pilot-Operated Check valve Inline body</p> | <p>4 控制活塞的密封方式 Sealing Method of Pilot Piston
00=No O-Ring 控制活塞无 "O" 型圈
10=With O-Ring 控制活塞带 "O" 型圈</p> | <p>6 阀块油口 Body Porting
3G=G 3/8
其它螺纹油口也是可选择的
Other Porting is Available</p> |
| <p>2 连接类型 ConnectionType</p> | <p>5 阀块材料 Body Material
A=Aluminum, 210bar
(Omit for steel,350bar)</p> | <p>7 开启压力 Crack Pressure
8=8bar 4.5=4.5bar 3=3bar 00=1.0bar</p> |