

# LSLV-10

## 梭阀

### 说明 DESCRIPTION

A cartridge-style ball-type shuttle valve

球型螺纹插装式梭阀

### 工作 OPERATION

The valve will allow flow from the higher pressure of port ① or ③ to the port ②. The valve is commonly used to direct oil from the pressure side of a bidirectional hydraulic motor to a pressure-released hydraulic brake.

当①口超过③口的压力时，①到②打开；

当③口超过①口的压力时，③到②打开。

一般用于自动开启液压马达制动器：比较液压马达油口压力，压力高的油口与液压制动器释放端连接。

### SYMBOL

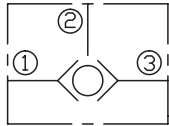

### 技术参数 SPECIFICATIONS

工作压力(Operating Pressure):	240bar
耐压压力(Proof Pressure):	390bar
流量(Flow):	See PRESSURE DROP VS.FLOW graph.
内泄漏(Internal Leakage):	5 drops/min(滴/分). max. at 207bar
温度(Temperature):	-40°F to +250°F(-40°C to +120°C)
过滤(Filtration):	See page (参见) N-1
油液(Fluids):	Mineral-based fluids with viscosities of 7.4 to 420 cSt.(矿物油粘度)
插孔(Cavity):	10-3, See page M-2
阀块材料(Body Material):	6061-T6 aluminum alloy rated to 207bar, Steel & Ductile iron rated to 350bar 6061-T6铝,允许使用最大压力207bar 钢和球铁允许使用最大压力350bar

### 压力 - 流量曲线 PRESSURE DROP VS.FLOW

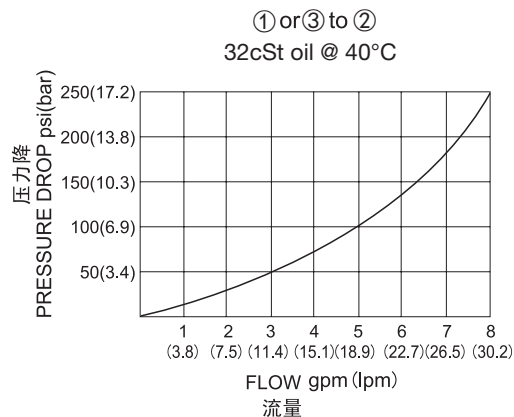
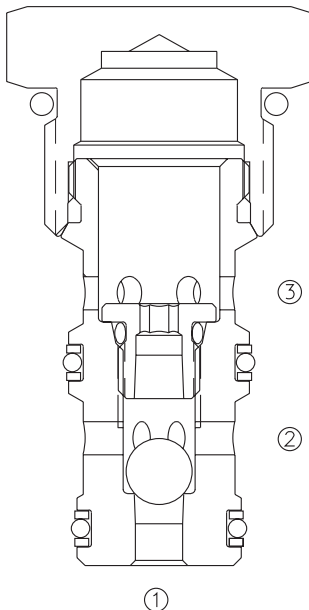

订货代号 TO ORDER

**LSLV - 10 - \* \***

┌───┐  
1

┌───┐  
2

┌───┐  
3

**1** 功能  
LSLV= 梭阀 Ball Type, Cartridge Shuttle Valve

**2** 规格 Size  
10=10 规格

**3** 阀块油口 **Body Porting**  
空白 Blank= 不带阀块 None  
6T=SAE6  
8T=SAE8  
2G=G 1/4  
3G=G 3/8

※ 阀块详见章节 K-5  
其它螺纹油口也是可选择的  
Other Porting is Available

D

安装尺寸 **INSTALLATION DIMENSIONS**

Unit=Millimeters

