

LSV2-10-4 NC

二位四通电磁阀 常闭型

说明 DESCRIPTION

A solenoid operated, 4-way, 2-position, normally closed spool-type cartridge valve
二位，四通，滑阀式电磁阀

工作 OPERATION

When de-energized, the valve flows paths are blocked. When energized, the cartridge's spool shifts to allow flow from ③ to ④ or from ④ to ③ and from ② to ① or from ① to ②.

失电时，①②③④都关闭；得电时，③和④通，②和①通。

手控应急 Operation of Manual Override Option

To override, push button in, twist counterclockwise 180° and release. In this position, valve will remain detented in the shifted condition. To return to normal operation, push button in, twist clockwise 180° and release. Override will be detented in this position.

请按下按钮，再逆时针方向旋转 180°，后松开，③和④通，②和①通；请按下按钮，再顺时针方向旋转 180°，后松开，返回常态。

SYMBOL

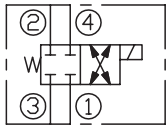

技术参数 SPECIFICATIONS

工作压力 (Operating Pressure):	207bar
流量 (Flow):	See PRESSURE DROP VS.FLOW graph.
内泄漏 (Internal Leakage):	82 cc/min.(毫升/分) max. at 207bar
温度 (Temperature):	-40°F to +212°F(-40°C to +100°C)
线圈额定负载 (Coil Duty Rating):	Continuous from 85% to 115% of nominal voltage(连续工作电压)
过滤 (Filtration):	See Page (参见) N-1
油液 (Fluids):	Mineral-based fluids with viscosities of 7.4 to 420 cSt.(矿物油粘度)
插孔 (Cavity):	10-4, See page M-2
阀块材料 (Body Material):	6061-T6 aluminum alloy rated at 207Bar, Steel & Ductile iron rated at 350Bar 6061-T6铝, 允许使用最大压力207Bar 钢和球铁允许使用最大压力350Bar

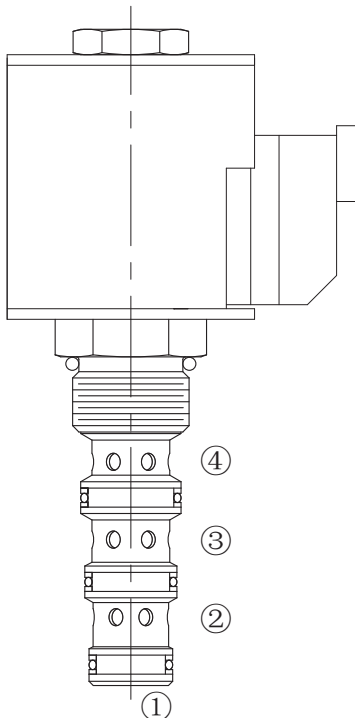

压力 - 流量曲线 PRESSURE DROP VS.FLOW

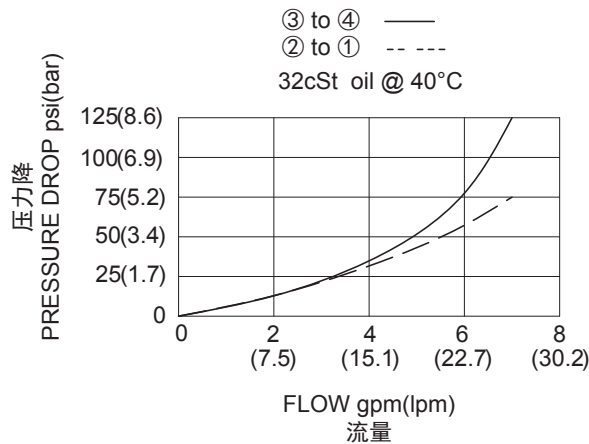

LSV2 - 10 - 4 NC - * - * * - * *

┌───┐
┌───┐
┌───┐
┌───┐
┌───┐
┌───┐
┌───┐
┌───┐

1
2
3
4
5
6
7
8

<p>1 功能 LSV2= 电磁阀 Solenoid Valve</p>	<p>6 电压 Voltage 1=12 VDC 2=24 VDC 3=110 VAC 4=220 VAC 5=10 VDC</p>	<p>8 阀块油口 Body Porting 空白 Blank= 不带阀块 None 6T=SAE6 8T=SAE8 2G=G 1/4 3G=G 3/8</p>
<p>2 规格 Size 10=10 规格</p>	<p>7 线圈连接 Coil Connection D= Double Lead 双线 H= Hirschmann 三插 C= Conduit 带嵌套 ER= Deutsch Connector(Water-proof Coil) 德意志插座 (防水线圈) B= Double Spade 双插</p>	<p>※ 阀块详见章节 K-6 其它螺纹油口也是可选择的 Other Porting is Available</p>
<p>3 流道类型 Flow Path 4= 四通</p>		
<p>4 模式 NC= 常闭 Normally Closed</p>		
<p>5 手控应急 空白 Blank= 无手控应急 None M= 手控应急 Manual Override</p>		

安装尺寸 INSTALLATION DIMENSIONS

Coil Must Be Installed With Letter Up
安装线圈时，字母必须朝上。

Unit=Millimeters

