

SCB-LMB2-SE30G-3G

单向平衡阀组



说明 DESCRIPTION

Single counterbalance manifolds

单向平衡阀

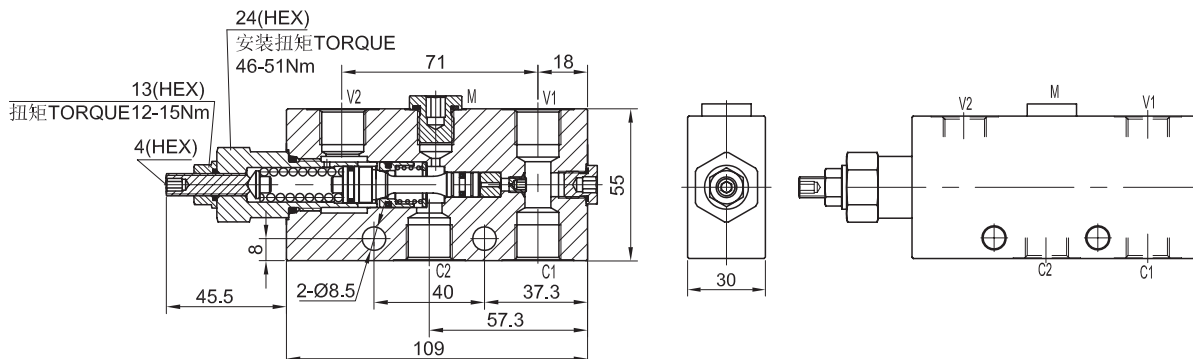

工作 OPERATION

When pressure at V2 rises above the spring bias pressure, the check seat is pushed away from the piston and flow is allowed from V2 to C2 .When load pressure at C2 rises above the pressure setting, the direct operated, differential area ,relief function is activated and flow is relieved from C2 to V2. With pilot pressure at V1-C1, the pressure setting is reduced in proportion to the stated ratio of the valve, until opening and allowing flow from C2 to V2. The spring chamber is drained to V2, and any back-pressure at V2 is additive to the pressure setting in all functions.

当 V2 口压力升高超过单向阀开启压力时，单向阀 V2 口到 C2 口开启。当 C2 口负载压力升高超过弹簧的设定值时，C2 口到 V2 口过载溢流。当先导 V1-C1 口有先导压力的情况下，压力设定根据阀的液控比成比例降低，直到开启并允许油液从 C2 流向 V2。弹簧腔与 V2 口连通，V2 口的任何背压都添加到所有功能的压力设定。

SYMBOL

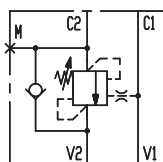

技术参数 SPECIFICATIONS

最大工作压力(Max.Operating Pressure):	350bar
流量(Flow):	See PRESSURE DROP VS.FLOW graph.
控制比(Pilot Ratio):	4.2:1
内泄漏(Internal Leakage):	5 drops/min(滴/分). at nominal pressure
温度(Temperature):	-40°F to +250°F(-40°C to +120°C)
过滤(Filtration):	See page (参见) N-1
油液(Fluids):	Mineral-based fluids with viscosities of 7.4 to 420 cSt.(矿物油粘度)
阀块材料(Body Material):	Steel & Ductile iron rated to 350bar 钢和球铁允许使用最大压力350bar

压力 - 流量曲线 PRESSURE DROP VS.FLOW

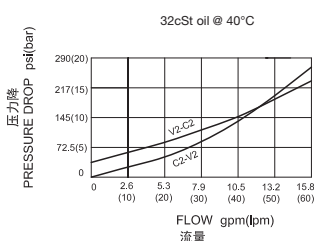

订货代号 TO ORDER

SCB - LMB2 - SE30G - 3G - * *



1 功能 SCB= 单向平衡阀 Single Counterbalance Manifolds	5 阀块油口 Body Porting 3G=G 3/8 其它螺纹油口也是可选择的 Other Porting is Available	6 调压范围 Spring Ranges 35=1450-5000psi(100-350bar) Preset:5000psi(350bar) 130bar/ 圈 21=870-3000psi(60-210bar) Preset:3000psi(210bar) 65bar/ 圈 固定设定值 psi(bar) Q=5l/min
2 连接类型 ConnectionType		
3 规格 Size		
4 液控比 Pilot Ratio G=4.2:1		